



**agriculture  
& rural development**

Department:  
agriculture  
& rural development  
**PROVINCE OF KWAZULU-NATAL**

**KWAZULU-NATAL DEPARTMENT OF AGRICULTURE AND RURAL  
DEVELOPMENT**

**Quotation No: R/S/1920/1779**

**SUPPLY, DELIVER AND ERECT FENCING SIYAQHUBEKA PROJECT**

**NAME OF BIDDER: \_\_\_\_\_**

<b>COMPULSORY SITE BRIEFING DETAILS</b>	
<b>DATE</b>	17 FEBRUARY 2020
<b>MEETING VENUE</b>	AUDITORIUM
<b>MEETING ADDRESS</b>	1 CEDARA ROAD ,
<b>MEETING TIME</b>	
<b>START TIME</b>	11:00 AM

**1. PRE-QUALIFICATION CRITERIA**

**REQUIREMENT-CIDB Grading: 1 SQ/ GB / ME / CE**

**Evaluation will be in terms of the 80/20 preference point system**

**For more information, please contact the following official:**

**For: Technical Enquiries:  
RM MKHIZE  
076 821 6543**

**For: Quotation/SCM enquiries:  
Ms Bonnie Nzimande**

**CLOSING DATE: 24 FEBRUARY 2020 TIME: 11:00 AM**



# agriculture & rural development

Department:  
agriculture  
& rural development  
**PROVINCE OF KWAZULU-NATAL**

## INVITATION OF QUOTATION ABOVE R30,000.00

THIS FORM SHOULD BE COMPLETED IN DETAIL AND SHOULD BE ACCOMPANIED BY A **VALID TAX COMPLIANCE STATUS PIN AND VALID BBEE VERIFICATION CERTIFICATE/AFFIDAVIT**

QUOTATION NUMBER: R/S/1920/1779	VALIDITY PERIOD OF QUOTATION..... Days (To be completed by the Supplier)
CLOSING DATE: 24 FEBRUARY 2020	CLOSING TIME:11H00
DESCRIPTION(SPECIFICATION/S) OF ITEMS/ SERVICE REQUIRED: <b>Supply , deliver and Erect fencing Siyaqhubeka project</b>	COMPANY NAME:  TEL NO: FAX NO:  CONTACT PERSON:  <b>CSD REG NUMBER</b> <b>MAAA.....</b>
DOES OFFER COMPLY WITH SPECIFICATION?	YES/NO (DELETE WHICH EVER IS NOT APPLICABLE)
DOES ARTICLE COMPLY WITH SABS SPECIFICATION? HAS IT BEEN INSPECTED BY SABS?	YES/NO YES/NO (DELETE WHICH EVER IS NOT APPLICABLE)
DELIVERY PERIOD AFTER INITIAL ORDER?	
IS THE PRICE FIRM	
WHERE ARE THE STOCK HELD? (PHYSICAL ADDRESS , PLEASE)	
QUOTATION PRICE INCLUDING VAT (VAT TO BE ADDED BY REGISTERED VAT VENDORS ONLY)	TOTAL: R .....
COMPANY OFFICIAL STAMP (COMPULSORY)	..... SIGNATURE OF BIDDER  ..... DATE
NUMBER OF PAGES SUBMITTED BACK TO THE DEPARTMENT BY THE SUPPLIER	.....( Supplier to complete)

**NB:** QUOTATION FOR THE ATTENTION OF: Bonnie Nzimande  
TELEPHONE NUMBER: 033 343 8311

**NB:**  
THE ATTACHED SBD4 & SBD9 FORMS MUST BE COMPLETED IN FULL.  
THIS REQUEST FOR QUOTATION (RFQ) MUST BE COMPLETED AND RETURNED WITH ALL YOUR QUOTATION DOCUMENTS.

**QUOTATIONS MUST BE DEPOSITED IN THE BID BOX SITUATED AT: THE DEPARTMENT OF AGRICULTURE & RURAL DEVELOPMENT: SCM OFFICES: 4 PIN OAK AVENUE , LOWER QUARY**

1779

ANNEXURE A

COMPANY NAME : \_\_\_\_\_  
 ADDRESS : \_\_\_\_\_  
 CONTACT PERSON : \_\_\_\_\_  
 CONTACT NUMBER : \_\_\_\_\_  
 FAX NUMBER : \_\_\_\_\_

For Supply, deliver, offload and erect 2km fence for small holder Siyaqhubeka goat project as per specification attached.

LINE NO.	DESCRIPTION OR SPECIFICATION OF ITEM  (Please be very specific and clear)	REQUIR ED QUANTI TY	UNIT PRICE EXCL. VAT		TOTAL PRICE	
			R	C	R	C
1.	As per specification.					
	For Supply, deliver, offload and erect 2km fence for small holder Siyaqhubeka goat project	1				
* LABOUR (IF APPLICABLE)						
*DELIVERY (IF APPLICABLE)						
TOTAL						
*ONLY APPLICABLE TO VAT REGISTERED SUPPLIERS 15% VAT						
TOTAL PRICE						

\*VAT Registration No. (Supplier) -----  
 When Required (Requester) : 31 July 2019  
 Where Required (Requester) : Nkaseni  
 Contact details of requester : Gayi T.G  
 TEL : 076 967 5346

Mark one Box (X)

COMPANY STAMP

PRICES ARE VALID FOR

DAYS



30

60

90

SIGNATURE .....

DATE .....



**NINE STRANDS BARBED WIRE FENCE WITH WOODEN POSTS 15M APART**

>>> SUPPLY AND ERECTION <<<

**BID DOCUMENT**

**Project: Siyaqhubeka Goats Project**

**TABLE OF CONTENTS:**

No.	Section	Pages	Read / Complete
1.	Project Particulars and Specification	1-3	Read
2.	Bill of Quantities	4	Complete
3.	Drawing A1	5	Read
4.	Map of fence layout	6	Read

Appointment of a Service Provider to SUPPLY AND ERECT

2.00

kms of barbed  
wire fence at

**SIYAQHUBEKA GOATS  
PROJECT**

**1. Background:**

The fence is to be erected approximately

25

km from

Estcourt CBD

**2. Specific Objective:**

Supply & deliver materials for and fully erect a six strand barbed wire fence of

2000

m length.

The fence must be erected in accordance with the specification in the attached drawing, Drawing RDN/2013/08/FEN

**3. Scope of Objectives:**

Supply all materials for and erect a 1.5m high 9 strand barbed wire fence.

The following services are required:

- 3.1 **Supply:** - of the specified materials listed in the Bill Of Quantities, Appendix 1.
- 3.2 **Delivery:** - of all materials to **SIYAQHUBEKA GOATS PROJECT**
- 3.3 **Erection:**
  - according to the attached map, showing the fence layout.
  - according to the Departmental Specifications in the attached drawing, Drawing A1.
  - providing all equipment required for erection
  - sourcing of at least 50% unskilled labour from the local community.
- 3.4 **Inspection and reporting:**
  - Weekly inspection reports of progress must be submitted on Monday morning to the contact person.
  - On site inspections will be conducted by Departmental staff to check all completed work before any payments can be made
  - The contractor is responsible to check that the tendered distance is correct. Failure to check the distance before starting the installation will result in the contractor not being paid for any excess/extra material that the contractor has purchased. The contractor will only be paid for materials that have been used. Where the tendered distance is lower than the required distance the contractor must not exceed the tender amount prior to receiving authorization in the form of a variation order.
  - Accurate distances of all erected fences are to be kept by the service provider as only work that has been done will be paid for. Any fencing installed over the order amount will not be paid for unless prior permission has been obtained to exceed the order amount.
  - Site meetings and project steering committee meetings to be held when necessary and minutes to be kept by the SP

**4. Deliverables:**

- 4.1 Fencing materials according to the Bill of Quantities in Appendix 1.
- 4.2 Construction of the fence according to the specifications provided in Drawing A1. If Drawing A1 was not attached to the tender documents
- 4.3 it is the contractors responsibility to obtain the drawing before submitting the tender. Failure to erect the fence according to the Departmental
- 4.4 specification will result in the contractor having to re-install the fence at the contractors own expense.
- 4.5 Weekly written progress reports to the Local Agricultural Manager, outlining progress, daily activities and quantities of materials used.
- 4.6 Submission of full closeout report including materials used, job opportunities created in EPWP format for the duration of the project.
- 4.7 Attendance of steering committee meetings and the provision of minutes if called for.
- 4.8 The contract requires a minimum delivery of 3 km of completed fencing per week.
- 4.9 Any excess material STRICTLY to be left with the project beneficiaries.

**BID DOCUMENT PAGE 2**

**5. Competence and Expertise:**

It is essential that the work be carried out by fully competent personnel with proven experience in fencing and Project Management.

- 5.1 **Competency:**
  - only bidders with proven ability to complete 3 km per week shall be considered.
  - bidders are required to provide an implementation plan including time frames from start to finish.
  - failure to provide a program will invalidate the bid.
- 5.2 **Labour:**
  - \* skilled and semi-skilled labour only to be provided by the contractor. At least 50% unskilled labour is to be sourced from the local community.
- 5.3 **Site supervision**
  - \* Project Manager/Technician on site to supervise work done, quality control and certify work for payment.
- 5.4 **Bid Format:**
  - Estimated time for processing payments after submission of the invoice to the Finance section is 2-4 weeks.
  - All documents in the bid document are to be completed. All quotations and claims must include VAT.

# NINE STRANDS BARBED WIRE FENCE WITH WOODEN POSTS 15M APART

>>> SUPPLY AND ERECTION <<<

## BID DOCUMENT - Page 2

### 6. Validity Period for Bid:

Bids shall remain valid for a period of 90 days from the date that the bid closes.

### 7. Compulsory Pre-Bid Tender Meeting:

A compulsory pre-bid site meeting will be held with prospective bidders. Failure to attend this meeting will invalidate the bid.

### 8. Site Hand Over to the Contractor:

The contractor will be introduced to the project participants following the awarding of the tender. The site will be handed over to the contractor who will control the site for the duration of the project. The contractor will be responsible for the administration, control and security for the site. It is up to the contractor to arrange insurance as the contractor is responsible for and theft or damage that occurs on site and will have to pay for any repairs or replacements.

### 9. Water and Electricity:

There is no piped water and electricity on site. The contractor shall make the necessary arrangements for the provision of any water and electricity. Any cost to acquire water and electricity must be added to the bid amount as no extra funding will be received.

### 10. Housing of Contractors Employees:

No housing is available for the contractors employees and the contractor shall make arrangements to and from site. It is up to the contractor to arrange any short term accommodation with the project participants. The contractor is responsible for any financial expenses for housing employees on site.

### 11. Underground Cables and Pipes:

If such services are discovered, immediate notification must be made to the Employer and all work in the vicinity will cease until it is safe to continue. If the contractor damages any underground pipes or cables such damage will be repaired as soon as it is safe and possible by the

### 12 Insurance

All accepted approved contractors shall be required to provide the following insurance's for the project awarded to them:

- i) Registration with the Compensation Commissioner and compliance with the Compensation for Occupational Injuries and Diseases Act with regard to insurance.
- ii) Unemployment fund insurance for all workers.
- iii) Insurance against damage, destruction or loss caused by fire.
- iv) Public Liability insurance.
- v) All Risks (works) Policy Political for the value of the respective project plus 10%.

### 13. Specifications:

Refer to Bill of Quantities and Drawings .

- **Spacing wooden poles: 15m. Droppers at 3.0m. 4 droppers in between 2 poles.**  
10% maximum deviation (1.5m/0.3m) from the specified spacings will be allowed.
- **Boxes: Box length to be 1.05m (half a pole length).**
- **Compaction :** Normal manual force against the poles must be absorbed.
- **Straining:** All strands of barbed wire to be strained. If the fence is pulled down, it must recover to its original position. Fence is to be strained using appropriate straining equipment.
- **Exposed Surfaces :** All exposed surfaces where poles have been sawed off are to be painted with creosote.

### 14. Timetable/Timing:

The contractor must be on site and commence construction no later than 1 week after an order has been issued. Where more than 1 payment is required, the contractor must indicate the number of part payments that will be required in the tender documents. Claims for work that has been completed and verified can be submitted on a monthly basis. No more than 1 claim per month will be accepted.

### 15. Management Arrangements and Reporting Requirements:

**P Jele** is the District Director. Any matters regarding the district staff or any complaints should be directed to her.

### 16. Evaluation Criteria:

Proven previous experience is a requirement to qualify.

The following minimum CIDB designations are required:

Farm fencing (barbed/razor wire/hinged joint) < 5km:	1SQ/CE/GB
Farm fencing (barbed/razor wire/hinged joint) 5 - 15km:	2SQ/CE/GB
Farm fencing (barbed/razor wire/hinged joint) > 15km:	3SQ/CE/GB

**Table 1A**  
Minimum CIDB designation requirements per length of fencing bracket

Award of work to the successful bidder will be based on Price, Departmental Goals, i.e. preference points as per BBBEE status (see section 16.2 below) and functionality.

#### 16.1 Compliance:

- i) All information and documentation required in the Specification, eg. Certificates.
- ii) All information required in the bid document must be accurate and duly completed, including all the appropriate signatures. This includes the submission of required / requested documentation eg. valid tax certificate, etc.
- iii) Failure to comply with any of the requirements will invalidate the bid.



**NINE STRANDS BARBED WIRE FENCE WITH WOODEN POSTS 15M APART**

>>> SUPPLY AND ERECTION <<<

**BID DOCUMENT - Page 3**

**16.2 The 80/20 and 90/10 Preference Points System:**

(i) Depending on the bid value either the 80/20 (for bids up to R 1,000,000) or the 90/10 point preference point system (for bids of R 1,000,000

**(ii) CALCULATION OF POINTS FOR ATTAINING THE B-BBEE STATUS LEVEL**

B-BBEE Status Level of contributor	Number of points (80/20 system)	Number of points (90/10 system)
1	10	20
2	9	18
3	8	16
4	5	12
5	4	8
6	3	6
7	2	4
8	1	2
Non-compliant bidder	0	0

This will be done in accordance with the "PREFERENTIAL PROCUREMENT POLICY FRAMEWORK ACT, 05 OF 2000 AND REGULATION OF 2011". Points will be awarded to a bidder for attaining the B-BBEE status level contributor. Table 2 shows the points to be allocated at different levels.

**PLEASE NOTE:** Bidders are required to, together with their bids, submit original and valid B-BBEE Status Level Verification Certificates or certified copies thereof to substantiate their B-BBEE rating claims. Bidders who do not submit B-BBEE Status Level Verification Certificates do not qualify for preference points for B-BBEE but will not be disqualified from the bidding process for non-compliance in this regard.

**TABLE 1B: Preference points per BBEE status level**

**(iii) FUNCTIONALITY**

Functionality will be assessed separately from the 90/10 or 80/20 formula. The first stage will be the assessment of functionality upon which the Bidders who score less than 65% for functionality will not be considered further.

The second stage will be the assessment and evaluation of Bidders in terms of 90/10 or 80/20, where 90 (80) points shall be used for pricing scores only and the 10 (20) points for BBEE status. See Tables 2 and 3 for Evaluation Guidelines and Criteria respectively.

Submissions will be scored using the below scoring table. This bid will be evaluated on functionality which will determine the capability, ability and capacity of the prospective bidders to provide the required goods or services for the department. A minimum score of 65% must be obtained by the bidder in order to qualify to be evaluated further for price.

**TABLE 2: GUIDELINES FOR EVALUATION**

CRITERIA	GUIDELINES FOR EVALUATION
<b>ABILITY</b> Capacity	Bidders to provide proof of current capacity and ability to: Implement the design and specifications to the standard as directed in the technical specifications.
<b>CAPABILITY</b> Competency Experience	Demonstration of competency to render the required service & providing proof of registration with the CIDB (For min. CIDB designation requirements see Table 1A) Bidders to provide evidence of similar projects completed recently i.e. not less than 2 projects and not more than 5 projects in the past 5 years.
<b>METHODOLOGY</b>	Provide a short description of your intended implementation methodology indicating time frames to complete the work.
<b>NOTE:</b> In order to ensure meaningful evaluation, bidders must submit detailed information in substantiation of the evaluation criteria mentioned.	

**TABLE 3: ASSESSMENT CRITERIA FOR THE EVALUATION OF THE FUNCTIONALITY**

EVALUATION MATRIX		Points %	Score
1	Financial viability of the bidder: Submission of a letter of good standing from a recognized financial institution	10	
2	Submission of short CV's of key personnel.	20	
3	• Demonstration of competency to render the required service (e.g. CIDB registration certificates),	10	
	• Providing proof of Insurances,	5	
	• Proof of compliance with Labour legislation (enrolment of staff for Workman's compensation/UIF, Occupational Health & Safety Act.	10	
4	Demonstrable experience of the prospective service provider's engagement in similar work:		
	• Submission of list of 2 - 5 projects in the last 5 years with values and extent of involvement and contact details of referees.	25	
	• Documentary proof such as reference letters/CIDB assessments indicating value and period of the contract.	10	
5	Submission of a short description of the intended implementation methodology indicating time frames to complete work.	10	
<b>TOTAL</b>		<b>100%</b>	

**NINE STRANDS BARBED WIRE FENCE WITH WOODEN POSTS 15M APART**>>> **SUPPLY AND ERECTION** <<<**BID DOCUMENT PAGE 4****16.3 General:**

The Department of Agriculture, Environmental Affairs and Rural Development is an equal opportunity, affirmative action employer. It shows the same commitment to those who wish to provide services to the Department via the procurement process. This does not preclude the formation of consortiums or the inclusion of proposals on how this project can be used to further the aims of transformation.

The actual price quoted, including VAT, will be used for issuing of an order to the successful bidder. You must provide for all items in Appendix 1 as the unit rates quoted will be applied for calculation of the amount claimable.

**17. Payment Schedule:**

Claims for work that has been completed can be made according to the following payment schedule:

1 Site Establishment:	5%
2 Material delivered to site (with invoice)	Invoiced Amount
3 Completed sections of fence (per m)	pro rata tender amount (less 1+2+4)
4 Retention	5%

A 5% retention will be kept for 1 month after works have been completed to make sure that the standard of work that has been done is satisfactory.

**18. Enquiries:**

**P Jele** District Director  
**TS Masengemi** Project manager

Contact Number **082 454 8004**  
Contact Number **076 937 3469**

## APPENDIX B: BILL OF QUANTITIES

Version 5.1- September 2016

Project: **Siyaqhubeka Goats Groject**

Fence Perimeter = **2000 m**

District **TS Masengemi**

Contact Person **076 937 3469**

Nearest town **Estcourt**

BOQ DATE **22/05/2019**

No.	Item Description	Quantity Required		Unit Price	Total Cost
1	Site establishment.	Sum	1		
2	<b>SITE CLEARING</b> Removal of old fences Bush clearing	Sum	1		
	<b>Materials:</b>				
3	Fully galvanized barbed wire 1.6mm diameter High Tensile Double Strand - 845m per roll	22	Roll(s)		
4	2.1m Standard Creosote Poles Pressure treated, SABS approved 100 - 125mmØ	160	Poles		
5	1.4m steel droppers	536	droppers		
6	Galvanized Wire Staples 3.15 x 32mm 500g packs	10	Pack(s)		
7	<b>Gate:</b> 900 (w) x 1200 (h)mm pedestrian gate Hot dip galvanized finish 40 - 50mm diam pipe frame wall thickness of 1.6mm min Hinge eye bolts, include chain	0	Gate(s)		
8	<b>Gate:</b> 3600 (w) x 1200 (h)mm Vehicle farm gate Hot dip galvanized finish 40 - 50mm diam pipe frame wall thickness of 1.6mm min Hinge eye bolts, include chain	0	Gate(s)		
9	<b>Gate:</b> 4.8m x 1200mm (h) tractor gate (2 frames of 2.4m per gate, HDG finish, 40-50mm diam. pipe frame, wall thickness 1.6mm min - hinge eye bolts - include chain	2	Gate (s)		
10	8 ga straining wire, 4mm diam, 5kg(50m) rolls Fully galvanised	16	Roll(s) of 5kg		
11	12 ga binding wire, 2.5mm diam, 5kg (130m) roll Fully galvanised	8	Roll(s) of 5 kg		
12	Erection Cost	Sum	1		
13	Transport Cost, including loading, delivery and off-loading near <b>Siyaqhubeka Goats Groject</b>	Sum	1		
		<b>SUB-TOTAL</b>			
		<b>VAT</b>			
		<b>TOTAL</b>			

**NOTE:** This Bill of Quantities must be read in conjunction with DRAWING REF RDN/2013/08/FEN Dated May 2013



6771

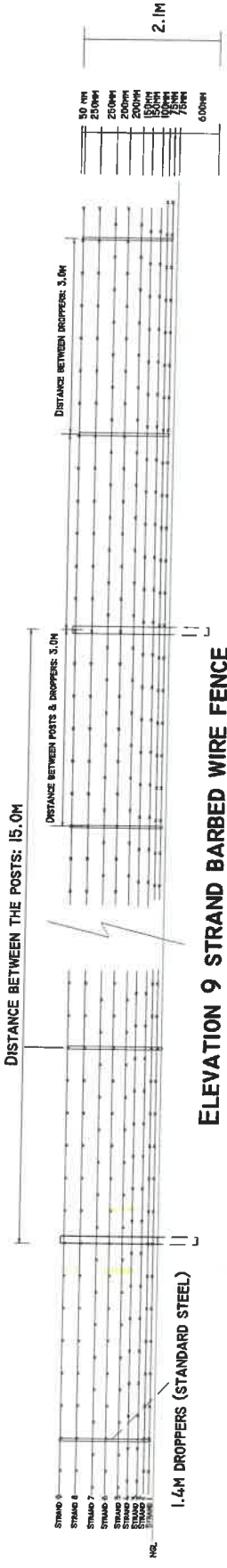

**ELEVATION 9 STRAND BARBED WIRE FENCE**

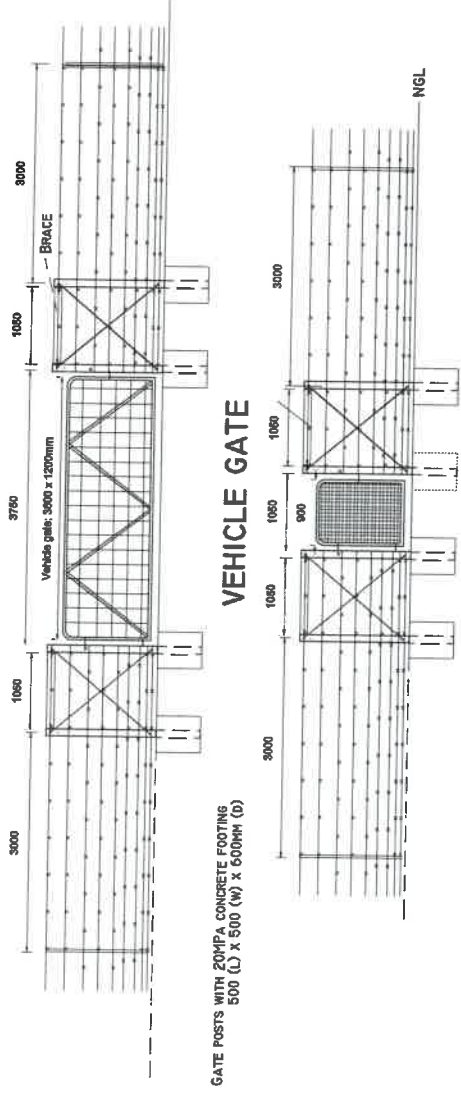

**VEHICLE GATE:**  
 3600 X 1200MM <->  
 40-50MM DIAM. PIPE FRAME <->  
 WALL THICKNESS 1.6MM MIN <->  
 MESH CLOSURE <->  
 HINGE EYE BOLTS <->  
 INCLUDE CHAIN >-<

**PEDESTRIAN GATE:**  
 1200 X 900MM <->  
 40-50MM DIAM. PIPE FRAME <->  
 WALL THICKNESS 1.6MM MIN <->  
 MESH CLOSURE <->  
 HINGE: EYE BOLTS ON POLE <->  
 INCLUDE CHAIN >-<

GATE POSTS WITH 20MPA CONCRETE FOOTING  
 500 (L) X 500 (W) X 600MM (D)

**PEDESTRIAN GATE**

**ALL FOLDS**  
 2.1M X 100-125MM DIAMETER

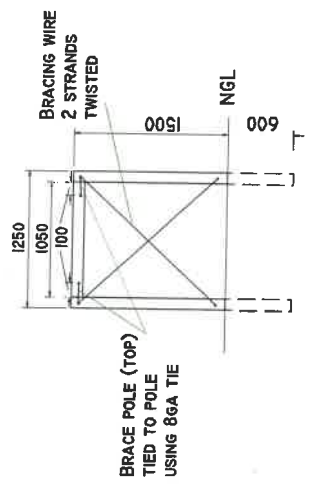

**STRAINING BOX  
DETAIL**

NOTE: CORNER BOX IS SIMILAR TO STRAINING BOX. USE 3 POLES AND 2 TOP BRACES

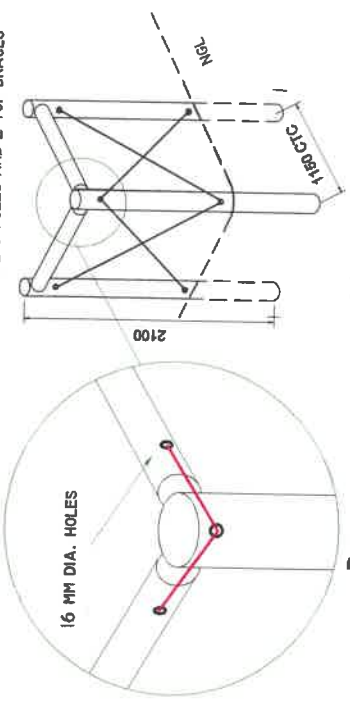

**CORNER BOX  
DETAIL**

- NOTES:**
- POLES PRESSURE TREATED CROCOATED (NOT PAINTED ON) 2.1M X 100 -125MM DIAMETER.
  - DROPPERS ARE STANDARD STEEL 1.4M LONG.
  - BARBED WIRE GALVANIZED, 1.6MM DIAMETER, DOUBLE STRAND - 84.5M ROLL.
  - THE FENCE SHOULD BE SECURED ONTO THE HARDWOOD POSTS AND BOXES BY MEANS OF 3.15 X 32 MM STAPLES.
  - THE STAPLES ARE TO BE INSTALLED OVER THE HORIZONTAL WIRES AT A 45 DEGREE ANGLE.
  - POLES TO BE PLACED IN HOLES 600MM DEEP AND VERY WELL COMPACTED WITH SOIL IN LAYERS (MAXIMUM SOIL LAYERS 100MM).
  - POLES ARE 15 M APART.
  - SANDY SOILS REQUIRE A REFILL OF SOIL CRETE = 10 %SOIL/CEMENT MIX.
  - DROPPERS 3 M APART (4 DROPPERS BETWEEN POLES).
  - DROPPERS TIED TO EACH STRAND WITH 12GA TIE WIRE.
  - HOLES DRILLED THROUGH POLES AS SHOWN FOR TIES ON INSERT IN DRAWING.
  - BOXES BRACED WITH DIAGONAL DOUBLE 8 GA WIRE STRANDS TWISTED TO TENSION.
  - ONE BOX EACH SIDE OF GATE. DOUBLE BOX AT CORNERS. ADDITIONAL BOXES AS REQUIRED OR EVERY LENGTH OF BARBED WIRE (MAX 100M APART).
  - PEDESTRIAN GATE - 0.9 X 1200 M.
  - BRACE OR "BOX" 1.05M WIDE. CUT ONE POLE IN HALF FOR TOPS.
  - MOTOR VEHICLE GATE - 3.6 X 1.2 M.
  - TENSION ON STRANDS MUST BE ADEQUATE USING WIRE STRAINER. ANCHOR END OF WIRE ON BOX BEFORE STRAINING.
  - NOTE: 7.2 ROLLS OF BARBED WIRE ARE REQUIRED PER KILOMETER OF FENCE.



**DEPARTMENT OF AGRICULTURE &  
 ENVIRONMENTAL AFFAIRS  
 ENGINEERING SERVICES**  
 PRIVATE BAG 60005, HILTON 5245  
 TEL: 085-5468800, FAX: 085-9495445

**DIMENSIONS  
 AS  
 INDICATED**

**CAD FILE NAME :**  
 NINE STRAND FENCE  
 15m POLE SPACING  
**DRAWING REFERENCE**  
 RDN/2014/01/FEN

**Drawn by: Robert de Neef  
 Date: 16 January 2014  
 Approved by: Erwin Koch**

**NINE STRAND FENCE  
 WITH 15 M POLE  
 SPACING**

**KINDLY COMPLETE PLEASE!!!**

**SBD 4**

**DECLARATION OF INTEREST**

1. Any legal person, including persons employed by the state<sup>1</sup>, or persons having a kinship with persons employed by the state, including a blood relationship, may make an offer or offers in terms of this invitation to bid (includes a price quotation, advertised competitive bid, limited bid or proposal). In view of possible allegations of favouritism, should the resulting bid, or part thereof, be awarded to persons employed by the state, or to persons connected with or related to them, it is required that the bidder or his/her authorised representative declare his/her position in relation to the evaluating/adjudicating authority where-

- the bidder is employed by the state; and/or
- the legal person on whose behalf the bidding document is signed, has a relationship with persons/a person who are/is involved in the evaluation and or adjudication of the bid(s), or where it is known that such a relationship exists between the person or persons for or on whose behalf the declarant acts and persons who are involved with the evaluation and or adjudication of the bid.

2. In order to give effect to the above, the following questionnaire must be completed and submitted with the bid.

2.1 Full Name of bidder or his or her representative: .....

2.2 Identity Number: .....

2.3 Position occupied in the Company (director, trustee, shareholder<sup>2</sup>): .....

2.4 Company Registration Number: .....

2.5 Tax Reference Number: .....

2.6 VAT Registration Number: .....

2.6.1 The names of all directors / trustees / shareholders / members, their individual identity numbers, tax reference numbers and, if applicable, employee / persal numbers must be indicated in paragraph 3 below.

<sup>1</sup>"State" means -

- (a) any national or provincial department, national or provincial public entity or constitutional institution within the meaning of the Public Finance Management Act, 1999 (Act No. 1 of 1999);
- (b) any municipality or municipal entity;
- (c) provincial legislature;
- (d) national Assembly or the national Council of provinces; or
- (e) Parliament.

<sup>2</sup>"Shareholder" means a person who owns shares in the company and is actively involved in the management of the enterprise or business and exercises control over the enterprise.

**KINDLY COMPLETE PLEASE!!!**

2.7 Are you or any person connected with the bidder presently employed by the state? **YES / NO**

2.7.1 If so, furnish the following particulars:

Name of person / director / trustee / shareholder/ member: .....  
Name of state institution at which you or the person connected to the bidder is employed : .....  
Position occupied in the state institution: .....

Any other particulars:  
.....  
.....  
.....

2.7.2 If you are presently employed by the state, did you obtain the appropriate authority to undertake remunerative work outside employment in the public sector? **YES / NO**

2.7.2.1 If yes, did you attached proof of such authority to the bid document? **YES / NO**

(Note: Failure to submit proof of such authority, where applicable, may result in the disqualification of the bid.

2.7.2.2 If no, furnish reasons for non-submission of such proof:

.....  
.....  
.....

2.8 Did you or your spouse, or any of the company's directors / trustees / shareholders / members or their spouses conduct business with the state in the previous twelve months? **YES / NO**

2.8.1 If so, furnish particulars:

.....  
.....  
.....

2.9 Do you, or any person connected with the bidder, have any relationship (family, friend, other) with a person employed by the state and who may be involved with the evaluation and or adjudication of this bid? **YES / NO**

**KINDLY COMPLETE PLEASE!!!**

2.9.1 If so, furnish particulars.

.....  
.....  
.....

2.10 Are you, or any person connected with the bidder, aware of any relationship (family, friend, other) between any other bidder and any person employed by the state who may be involved with the evaluation and or adjudication of this bid? **YES/NO**

2.10.1 If so, furnish particulars.

.....  
.....  
.....

2.11 Do you or any of the directors / trustees / shareholders / members of the company have any interest in any other related companies whether or not they are bidding for this contract? **YES/NO**

2.11.1 If so, furnish particulars:

.....  
.....  
.....

3 Full details of directors / trustees / members / shareholders.

Full Name	Identity Number	Personal Reference Number	Tax Number	State Number / Persal Number	Employee

**KINDLY COMPLETE PLEASE!!!**

**4 DECLARATION**

I, THE UNDERSIGNED (NAME).....

CERTIFY THAT THE INFORMATION FURNISHED IN PARAGRAPHS 2 and 3 ABOVE IS CORRECT.  
I ACCEPT THAT THE STATE MAY REJECT THE BID OR ACT AGAINST ME IN TERMS OF  
PARAGRAPH 23 OF THE GENERAL CONDITIONS OF CONTRACT SHOULD THIS DECLARATION  
PROVE TO BE FALSE.

.....  
Signature

.....  
Date

.....  
Position

.....  
Name of bidder

May 2011



**CERTIFICATE OF INDEPENDENT BID DETERMINATION**

- 1 This Standard Bidding Document (SBD) must form part of all bids<sup>1</sup> invited.
- 2 Section 4 (1) (b) (iii) of the Competition Act No. 89 of 1998, as amended, prohibits an agreement between, or concerted practice by, firms, or a decision by an association of firms, if it is between parties in a horizontal relationship and if it involves collusive bidding (or bid rigging).<sup>2</sup> Collusive bidding is a *pe se* prohibition meaning that it cannot be justified under any grounds.
- 3 Treasury Regulation 16A9 prescribes that accounting officers and accounting authorities must take all reasonable steps to prevent abuse of the supply chain management system and authorizes accounting officers and accounting authorities to:
  - a. disregard the bid of any bidder if that bidder, or any of its directors have abused the institution's supply chain management system and or committed fraud or any other improper conduct in relation to such system.
  - b. cancel a contract awarded to a supplier of goods and services if the supplier committed any corrupt or fraudulent act during the bidding process or the execution of that contract.
- 4 This SBD serves as a certificate of declaration that would be used by institutions to ensure that, when bids are considered, reasonable steps are taken to prevent any form of bid-rigging.
- 5 In order to give effect to the above, the attached Certificate of Bid Determination (SBD 9) must be completed and submitted with the bid:

<sup>1</sup> includes price quotations, advertised competitive bids, limited bids and proposals.

<sup>2</sup> bid rigging (or collusive bidding) occurs when businesses, that would otherwise be expected to compete, secretly conspire to raise prices or lower the quality of goods and / or services for purchasers who wish to acquire goods and / or services through a bidding process. Bid rigging is, therefore, an agreement between competitors not to compete.

**CERTIFICATE OF INDEPENDENT BID DETERMINATION**

I, the undersigned, in submitting the accompanying bid:

(Bid Number and Description)

in response to the invitation for the bid made by:

(Name of Institution)

do hereby make the following statements that I certify to be true and complete in every respect:

I certify, on behalf of: \_\_\_\_\_ that:  
(Name of Bidder)

1. I have read and I understand the contents of this Certificate;
2. I understand that the accompanying bid will be disqualified if this Certificate is found not to be true and complete in every respect;
3. I am authorized by the bidder to sign this Certificate, and to submit the accompanying bid, on behalf of the bidder;
4. Each person whose signature appears on the accompanying bid has been authorized by the bidder to determine the terms of, and to sign the bid, on behalf of the bidder;
5. For the purposes of this Certificate and the accompanying bid, I understand that the word "competitor" shall include any individual or organization, other than the bidder, whether or not affiliated with the bidder, who:

- (a) has been requested to submit a bid in response to this bid invitation;
- (b) could potentially submit a bid in response to this bid invitation, based on their qualifications, abilities or experience; and
- (c) provides the same goods and services as the bidder and/or is in the same line of business as the bidder

6. The bidder has arrived at the accompanying bid independently from, and without consultation, communication, agreement or arrangement with any competitor. However communication between partners in a joint venture or consortium<sup>a</sup> will not be construed as collusive bidding.
7. In particular, without limiting the generality of paragraphs 6 above, there has been no consultation, communication, agreement or arrangement with any competitor regarding:
  - (a) prices;
  - (b) geographical area where product or service will be rendered (market allocation)
  - (c) methods, factors or formulas used to calculate prices;
  - (d) the intention or decision to submit or not to submit, a bid;
  - (e) the submission of a bid which does not meet the specifications and conditions of the bid; or
  - (f) bidding with the intention not to win the bid.
8. In addition, there have been no consultations, communications, agreements or arrangements with any competitor regarding the quality, quantity, specifications and conditions or delivery particulars of the products or services to which this bid invitation relates.
9. The terms of the accompanying bid have not been, and will not be, disclosed by the bidder, directly or indirectly, to any competitor, prior to the date and time of the official bid opening or of the awarding of the contract.

<sup>a</sup> Joint venture or Consortium means an association of persons for the purpose of combining their expertise, property, capital, efforts, skill and knowledge in an activity for the execution of a contract.

**SBD 9**

10. I am aware that, in addition and without prejudice to any other remedy provided to combat any restrictive practices related to bids and contracts, bids that are suspicious will be reported to the Competition Commission for investigation and possible imposition of administrative penalties in terms of section 59 of the Competition Act No 89 of 1998 and or may be reported to the National Prosecuting Authority (NPA) for criminal investigation and or may be restricted from conducting business with the public sector for a period not exceeding ten (10) years in terms of the Prevention and Combating of Corrupt Activities Act No 12 of 2004 or any other applicable legislation.

.....  
**Signature**

.....  
**Date**

.....  
**Position**

.....  
**Name of Bidder**

Js914w 2

**OFFICIAL BRIEFING SESSION/SITE INSPECTION CERTIFICATE**

N. B.: THIS FORM IS ONLY TO BE INCLUDED AND COMPLETED WHEN APPLICABLE TO THE BID.

Site/building/institution involved:  
.....

Bid No: .....

Service: .....

\*\*\*\*\*

THIS IS TO CERTIFY THAT (NAME): .....

ON BEHALF OF: .....

VISITED AND INSPECTED THE SITE ON..... (DATE)

AND IS THEREFORE FAMILIAR WITH THE CIRCUMSTANCES AND THE SCOPE OF THE SERVICE TO BE RENDERED.

.....  
**SIGNATURE OF BIDDER OR AUTHORISED REPRESENTATIVE**  
(PRINT NAME)

**DATE:** .....

.....  
**SIGNATURE OF DEPARTMENTAL REPRESENTATIVE**  
(PRINT NAME)

.....  
**DEPARTMENTAL STAMP:**  
(OPTIONAL)

**DATE:** .....



Local Content

SBD 6.2

## DECLARATION CERTIFICATE FOR LOCAL PRODUCTION AND CONTENT FOR DESIGNATED SECTORS

This Standard Bidding Document (SBD) must form part of all bids invited. It contains general information and serves as a declaration form for local content (local production and local content are used interchangeably).

Before completing this declaration, bidders must study the General Conditions, Definitions, Directives applicable in respect of Local Content as prescribed in the Preferential Procurement Regulations, 2011, the South African Bureau of Standards (SABS) approved technical specification number SATS 1286:2011 (Edition 1) and the Guidance on the Calculation of Local Content together with the Local Content Declaration Templates [Annex C (Local Content Declaration: Summary Schedule), D (Imported Content Declaration: Supporting Schedule to Annex C) and E (Local Content Declaration: Supporting Schedule to Annex C)].

### 1. General Conditions

- 1.1. Preferential Procurement Regulations, 2011 (Regulation 9) makes provision for the promotion of local production and content.
- 1.2. Regulation 9.(1) prescribes that in the case of designated sectors, where in the award of bids local production and content is of critical importance, such bids must be advertised with the specific bidding condition that only locally produced goods, services or works or locally manufactured goods, with a stipulated minimum threshold for local production and content will be considered.
- 1.3. Where necessary, for bids referred to in paragraph 1.2 above, a two stage bidding process may be followed, where the first stage involves a minimum threshold for local production and content and the second stage price and B-BBEE.
- 1.4. A person awarded a contract in relation to a designated sector, may not sub-contract in such a manner that the local production and content of the overall value of the contract is reduced to below the stipulated minimum threshold.
- 1.5. The local content (LC) expressed as a percentage of the bid price must be calculated in accordance with the SABS approved technical specification number SATS 1286: 2011 as follows:

$$LC = [1 - x / y] * 100$$

Where

x is the imported content in Rand

y is the bid price in Rand excluding value added tax (VAT)

Prices referred to in the determination of x must be converted to Rand (ZAR) by using the exchange rate published by South African Reserve Bank (SARB) at 12:00 on the date of advertisement of the bid as indicated in paragraph 4.1 below.

**The SABS approved technical specification number SATS 1286:2011 is accessible on [http://www.thedti.gov.za/industrial development/ip.jsp](http://www.thedti.gov.za/industrial%20development/ip.jsp) at no cost.**

1.6 A bid may be disqualified if –

- (a) this Declaration Certificate and the Annex C (Local Content Declaration: Summary Schedule) are not submitted as part of the bid documentation; and
- (b) the bidder fails to declare that the Local Content Declaration Templates (Annex C, D and E) have been audited and certified as correct.

## 2. Definitions

- 2.1. **“bid”** includes written price quotations, advertised competitive bids or proposals;
  - 2.2. **“bid price”** price offered by the bidder, excluding value added tax (VAT);
  - 2.3. **“contract”** means the agreement that results from the acceptance of a bid by an organ of state;
  - 2.4. **“designated sector”** means a sector, sub-sector or industry that has been designated by the Department of Trade and Industry in line with national development and industrial policies for local production, where only locally produced services, works or goods or locally manufactured goods meet the stipulated minimum threshold for local production and content;
  - 2.5. **“duly sign”** means a Declaration Certificate for Local Content that has been signed by the Chief Financial Officer or other legally responsible person nominated in writing by the Chief Executive, or senior member / person with management responsibility (close corporation, partnership or individual).
  - 2.6. **“imported content”** means that portion of the bid price represented by the cost of components, parts or materials which have been or are still to be imported (whether by the supplier or its subcontractors) and which costs are inclusive of the costs abroad (this includes labour or intellectual property costs), plus freight and other direct importation costs, such as landing costs, dock duties, import duty, sales duty or other similar tax or duty at the South African port of entry;
  - 2.7. **“local content”** means that portion of the bid price which is not included in the imported content, provided that local manufacture does take place;
  - 2.8. **“stipulated minimum threshold”** means that portion of local production and content as determined by the Department of Trade and Industry; and
  - 2.9. **“sub-contract”** means the primary contractor’s assigning, leasing, making out work to, or employing another person to support such primary contractor in the execution of part of a project in terms of the contract.
3. **The stipulated minimum threshold(s) for local production and content (refer to Annex A of SATS 1286:2011) for this bid is/are as follows:**

<u>Description of services, works or goods</u>	<u>Stipulated minimum threshold</u>
Fencing (wire products)	100 %
_____	_____ %
_____	_____ %

4. Does any portion of the services, works or goods offered have any imported content?  
(Tick applicable box)

YES	<input type="checkbox"/>	NO	<input type="checkbox"/>
-----	--------------------------	----	--------------------------

- 4.1 If yes, the rate(s) of exchange to be used in this bid to calculate the local content as prescribed in paragraph 1.5 of the general conditions must be the rate(s) published by SARB for the specific currency at 12:00 on the date of advertisement of the bid.

The relevant rates of exchange information is accessible on [www.reservebank.co.za](http://www.reservebank.co.za).

Indicate the rate(s) of exchange against the appropriate currency in the table below (refer to Annex A of SATS 1286:2011):

<b>Currency</b>	<b>Rates of exchange</b>
US Dollar	
Pound Sterling	
Euro	
Yen	
Other	

NB: Bidders must submit proof of the SARB rate (s) of exchange used.

5. Were the Local Content Declaration Templates (Annex C, D and E) audited and certified as correct?  
(Tick applicable box)

YES	<input type="checkbox"/>	NO	<input type="checkbox"/>
-----	--------------------------	----	--------------------------

- 5.1. If yes, provide the following particulars:

- (a) Full name of auditor: .....
- (b) Practice number: .....
- (c) Telephone and cell number: .....
- (d) Email address: .....

(Documentary proof regarding the declaration will, when required, be submitted to the satisfaction of the Accounting Officer / Accounting Authority)

6. Where, after the award of a bid, challenges are experienced in meeting the stipulated minimum threshold for local content the dti must be informed accordingly in order for the dti to verify and in consultation with the AO/AA provide directives in this regard.

**LOCAL CONTENT DECLARATION**  
**(REFER TO ANNEX B OF SATS 1286:2011)**

**LOCAL CONTENT DECLARATION BY CHIEF FINANCIAL OFFICER OR OTHER LEGALLY RESPONSIBLE PERSON NOMINATED IN WRITING BY THE CHIEF EXECUTIVE OR SENIOR MEMBER/PERSON WITH MANAGEMENT RESPONSIBILITY (CLOSE CORPORATION, PARTNERSHIP OR INDIVIDUAL)**

**IN RESPECT OF BID NO.** .....

**ISSUED BY:** (Procurement Authority / Name of Institution):

.....  
**NB**

1 The obligation to complete, duly sign and submit this declaration cannot be transferred to an external authorized representative, auditor or any other third party acting on behalf of the bidder.

2 Guidance on the Calculation of Local Content together with Local Content Declaration Templates (Annex C, D and E) is accessible on <http://www.thdti.gov.za/industrial-development/ip.jsp>. Bidders should first complete Declaration D. After completing Declaration D, bidders should complete Declaration E and then consolidate the information on Declaration C. **Declaration C should be submitted with the bid documentation at the closing date and time of the bid in order to substantiate the declaration made in paragraph (c) below.** Declarations D and E should be kept by the bidders for verification purposes for a period of at least 5 years. The successful bidder is required to continuously update Declarations C, D and E with the actual values for the duration of the contract.

I, the undersigned, ..... (full names),  
do hereby declare, in my capacity as .....  
of .....(name of bidder  
entity), the following:

(a) The facts contained herein are within my own personal knowledge.

(b) I have satisfied myself that:

- (i) the goods/services/works to be delivered in terms of the above-specified bid comply with the minimum local content requirements as specified in the bid, and as measured in terms of SATS 1286:2011; and
- (ii) the declaration templates have been audited and certified to be correct.

(c) The local content percentage (%) indicated below has been calculated using the formula given in clause 3 of SATS 1286:2011, the rates of exchange indicated in paragraph 4.1 above and the information contained in Declaration D and E which has been consolidated in Declaration C:

Bid price, excluding VAT (y)	R
Imported content (x), as calculated in terms of SATS 1286:2011	R
Stipulated minimum threshold for local content (paragraph 3 above)	
Local content %, as calculated in terms of SATS 1286:2011	

**If the bid is for more than one product, the local content percentages for each product contained in Declaration C shall be used instead of the table above.**

**The local content percentages for each product has been calculated using the formula given in clause 3 of SATS 1286:2011, the rates of exchange indicated in paragraph 4.1 above and the information contained in Declaration D and E.**

(d) I accept that the Procurement Authority / Institution has the right to request that the local content be verified in terms of the requirements of SATS 1286:2011.

(e) I understand that the awarding of the bid is dependent on the accuracy of the information furnished in this application. I also understand that the submission of incorrect data, or data that are not verifiable as described in SATS 1286:2011, may result in the Procurement Authority / Institution imposing any or all of the remedies as provided for in Regulation 13 of the Preferential Procurement Regulations, 2011 promulgated under the Preferential Policy Framework Act (PPPFA), 2000 (Act No. 5 of 2000).

**SIGNATURE:** \_\_\_\_\_

**DATE:** \_\_\_\_\_

**WITNESS No. 1** \_\_\_\_\_

**DATE:** \_\_\_\_\_

**WITNESS No. 2** \_\_\_\_\_

**DATE:** \_\_\_\_\_



**Annex C**

**Local Content Declaration - Summary Schedule**

(C1) Tender No.  
 (C2) Tender description:  
 (C3) Designated product(s)  
 (C4) Tender Authority:  
 (C5) Tendering Entity name:  
 (C6) Tender Exchange Rate:  
 (C7) Specified local content %

Pula	EU	GBP
------	----	-----

**Note: VAT to be excluded from all calculations**

Tender item no's	List of items	Calculation of local content				Tender summary					
		Tender price - each (excl VAT)	Exempted Imported value	Tender value net of exempted Imported content	Imported value	Local value	Local content % (per item)	Tender Qty	Total tender value	Total exempted imported content	Total Imported content
(C8)	(C9)	(C10)	(C11)	(C12)	(C13)	(C14)	(C15)	(C16)	(C17)	(C18)	(C19)

Signature of tenderer: from Annex B \_\_\_\_\_  
 Date: \_\_\_\_\_

(C20) Total tender value  
 (C21) Total Exempt Imported content  
 (C22) Total Tender value net of exempt Imported content  
 (C23) Total Imported content  
 (C24) Total local content  
 (C25) Average local content % of tender

**Annex D**

**Imported Content Declaration - Supporting Schedule to Annex C**

(D1) Tender No. \_\_\_\_\_  
 (D2) Tender description: \_\_\_\_\_  
 (D3) Designated Products: \_\_\_\_\_  
 (D4) Tender Authority: \_\_\_\_\_  
 (D5) Tendering Entity name: \_\_\_\_\_  
 (D6) Tender Exchange Rate: \_\_\_\_\_ Pula \_\_\_\_\_

Note: VAT to be excluded from all calculations

EU R 9.00      GBP R 12.00

**A. Exempted imported content**

Calculation of imported content										Summary	
Tender Item no's	Description of Imported content	Local supplier	Overseas Supplier	Foreign currency value as per Commercial Invoice	Tender Exchange Rate	Local value of Imports	Freight costs to port of entry	All locally incurred landing costs & duties	Total landed cost excl VAT	Tender Qty	Exempted imp value
(D7)	(D8)	(D9)	(D10)	(D11)	(D12)	(D13)	(D14)	(D15)	(D16)	(D17)	(D18)
<b>(D19) Total exempt imported value</b>											

This total must correspond with Annex C - C 21

**B. Imported directly by the Tenderer**

Calculation of imported content										Summary	
Tender Item no's	Description of Imported content	Unit of measure	Overseas Supplier	Foreign currency value as per Commercial Invoice	Tender Rate of Exchange	Local value of Imports	Freight costs to port of entry	All locally incurred landing costs & duties	Total landed cost excl VAT	Tender Qty	Total Imported value
(D20)	(D21)	(D22)	(D23)	(D24)	(D25)	(D26)	(D27)	(D28)	(D29)	(D30)	(D31)
<b>(D32) Total imported value by tenderer</b>											

**C. Imported by a 3rd party and supplied to the Tenderer**

Calculation of imported content										Summary	
Description of Imported content	Unit of measure	Local supplier	Overseas Supplier	Foreign currency value as per Commercial Invoice	Tender Rate of Exchange	Local value of Imports	Freight costs to port of entry	All locally incurred landing costs & duties	Total landed cost excl VAT	Quantity Imported	Total Imported value
(D33)	(D34)	(D35)	(D36)	(D37)	(D38)	(D39)	(D40)	(D41)	(D42)	(D43)	(D44)
<b>(D45) Total imported value by 3rd party</b>											

**D. Other foreign currency payments**

Calculation of foreign currency payments					Summary of payments
Type of payment	Local supplier making the payment	Overseas beneficiary	Foreign currency value paid	Tender Rate of Exchange	Local value of payments
(D46)	(D47)	(D48)	(D49)	(D50)	(D51)

Signature of tenderer from Annex B \_\_\_\_\_

Date: \_\_\_\_\_

(D52) Total of foreign currency payments declared by tenderer and/or 3rd party

(D53) Total of imported content & foreign currency payments - (D32), (D45) & (D52) above

This total must correspond with Annex C - C 23

### Annex E

## Local Content Declaration - Supporting Schedule to Annex C

(E1)	Tender No.	<input style="width: 95%;" type="text"/>
(E2)	Tender description:	<input style="width: 95%;" type="text"/>
(E3)	Designated products:	<input style="width: 95%;" type="text"/>
(E4)	Tender Authority:	<input style="width: 95%;" type="text"/>
(E5)	Tendering Entity name:	<input style="width: 95%;" type="text"/>

**Note:** VAT to be excluded from all calculations

Local Products (Goods, Services and Works)	Description of Items purchased	Local suppliers	Value
	(E6)	(E7)	(E8)
<b>(E9) Total local products (Goods, Services and Works)</b>			

(E10) **Manpower costs** (Tenderer's manpower cost)

(E11) **Factory overheads** (Rental, depreciation & amortisation, utility costs, consumables etc.)

(E12) **Administration overheads and mark-up** (Marketing, insurance, financing, interest etc.)

**(E13) Total local content**

This total must correspond with Annex C - C24

**Signature of tenderer from Annex B**

Date: \_\_\_\_\_